

Axpert KS Inverter



- Pure sine wave inverter
- Selectable input voltage range for home appliances and personal computers
- Selectable charging current based on applications
- Configurable AC/Solar input priority via LCD setting
- Compatible to mains voltage or generator power
- Parallel operation with up to 4 units only available for Axpert KS 5KVA*
- Auto restart while AC is recovering
- Overload and short circuit protection
- Smart battery charger design for optimized battery performance
- Cold start function

Axpert KS Inverter Selection Guide

MODEL	Axpert KS 1K	Axpert KS 2K	Axpert KS 3K	Axpert KS 4K	Axpert KS 5K
Rated Power	1000VA / 800W	2000VA/1600W	3000VA / 2400W	4000VA / 3200W	5000VA / 4000W
INPUT					
Voltage	230 VAC				
Selectable Voltage Range	170-280 VAC (For Personal Computers) 90-280 VAC (For Home Appliances)				
Frequency Range	50 Hz/60 Hz (Auto sensing)				
OUTPUT					
AC Voltage Regulation (Batt. Mode)	230VAC ± 5 %				
Surge Power	2000VA	4000VA	6000VA	8000VA	10000VA
Efficiency (Peak)	90%	93%			
Transfer Time	10 ms (For Personal Computers) 20 ms (For Home Appliances)				
Waveform	Pure sine wave				
BATTERY					
Battery Voltage	12 VDC	24 VDC	48 VDC		
Floating Charge Voltage	13.5 VDC	27 VDC	54 VDC		
Overcharge Protection	15 VDC	30 VDC	60 VDC		
Maximum Charge Current	10 A or 20 A	20 A or 30 A	20 A or 30 A		
SOLAR CHARGER (OPTION)					
Charging Current	50A				
Maximum PV Array Open Circuit Voltage	125 VDC				
Standby Power Consumption	1 W	2 W	2W		
PHYSICAL					
Dimension, D x W x H (mm)	95 x 240 x 316	100 x 272 x 355	115 x 295 x 455		
Net Weight (kgs)	5.0	6.4	6.9	9.8	9.8
OPERATING ENVIRONMENT					
Humidity	5% to 95% Relative Humidity(Non-condensing)				
Operating Temperature	0°C - 55°C				
Storage Temperature	-15°C - 60°C				

*Typical transfer time for parallel operation is 30ms.
Product specifications are subject to change without further notice

User Manual

4KVA/ 5KVA INVERTER / CHARGER

CONTENTS

ABOUT THIS MANUAL	1
Purpose.....	1
Scope.....	1
SAFETY INSTRUCTIONS.....	1
INTRODUCTION	2
Features.....	2
Basic System Architecture	2
Product Overview.....	3
Operation Diagrams and work conditions.....	4
INSTALLATION	7
Unpacking and Inspection.....	7
Preparation	7
Mounting the Unit.....	7
Battery Connection	8
AC Input/Output Connection.....	9
PV Connection (Only apply for the model with solar charger).....	10
Final Assembly.....	11
OPERATION	12
Power ON/OFF	12
Operation and Display Panel.....	12
LCD Display Icons	13
LCD Setting.....	15
Display Setting	16
Operating Mode Description	18
Fault Reference Code.....	19
Warning Indicator.....	20
SPECIFICATIONS	21
Table 1 Line Mode Specifications	21
Table 2 Invert Mode Specifications	22
Table 3 Charge Mode Specifications	23
Table 4 General Specifications	23
Charging Controls.....	23
TROUBLE SHOOTING	24
Appendix: Approximate Back-up Time Table	25

ABOUT THIS MANUAL

Purpose

This manual describes the assembly, installation, operation and troubleshooting of this unit. Please read this manual carefully before installations and operations. Keep this manual for future reference.

Scope

This manual provides safety and installation guidelines as well as information on tools and wiring.

SAFETY INSTRUCTIONS



WARNING: This chapter contains important safety and operating instructions. Read and keep this manual for future reference.

1. Before using the unit, read all instructions and cautionary markings on the unit, the batteries and all appropriate sections of this manual.
2. **CAUTION** --To reduce risk of injury, charge only deep-cycle lead acid type rechargeable batteries. Other types of batteries may burst, causing personal injury and damage.
3. Do not disassemble the unit. Take it to a qualified service center when service or repair is required. Incorrect re-assembly may result in a risk of electric shock or fire.
4. To reduce risk of electric shock, disconnect all wirings before attempting any maintenance or cleaning. Turning off the unit will not reduce this risk.
5. **CAUTION** – Only qualified personnel can install this device with battery.
6. **NEVER** charge a frozen battery.
7. For optimum operation of this inverter/charger, please follow required spec to select appropriate cable size. It's very important to correctly operate this inverter/charger.
8. Be very cautious when working with metal tools on or around batteries. A potential risk exists to drop a tool to spark or short circuit batteries or other electrical parts and could cause an explosion.
9. Please strictly follow installation procedure when you want to disconnect AC or DC terminals. Please refer to INSTALLATION section of this manual for the details.
10. Fuses (4 pieces of 30A, 150VDC for 4KVA and 5pcs of that for 5KVA) are provided as over-current protection for the battery supply.
11. GROUNDING INSTRUCTIONS -This inverter/charger should be connected to a permanent grounded wiring system. Be sure to comply with local requirements and regulation to install this inverter.
12. NEVER cause AC output and DC input short circuited. Do NOT connect to the mains when DC input short circuits.
13. **Warning!!** Only qualified service persons are able to service this device. If errors still persist after following troubleshooting table, please send this inverter/charger back to local dealer or service center for maintenance.

INTRODUCTION

This is a multi-function inverter/charger, combining functions of inverter, solar charger and battery charger to offer uninterruptible power support with portable size. Its comprehensive LCD display offers user-configurable and easy-accessible button operation such as battery charging current, AC/solar charger priority, and acceptable input voltage based on different applications.

Features

- Pure sine wave inverter
- Configurable input voltage range for home appliances and personal computers via LCD setting
- Configurable battery charging current based on applications via LCD setting
- Configurable AC/Solar Charger priority via LCD setting
- Compatible to mains voltage or generator power
- Auto restart while AC is recovering
- Overload/ Over temperature/ short circuit protection
- Smart battery charger design for optimized battery performance
- Cold start function

Basic System Architecture

The following illustration shows basic application for this inverter/charger. It also includes following devices to have a complete running system:

- Generator or Utility.
- PV modules (option)

Consult with your system integrator for other possible system architectures depending on your requirements.

This inverter can power all kinds of appliances in home or office environment, including motor-type appliances such as tube light, fan, refrigerator and air conditioner.

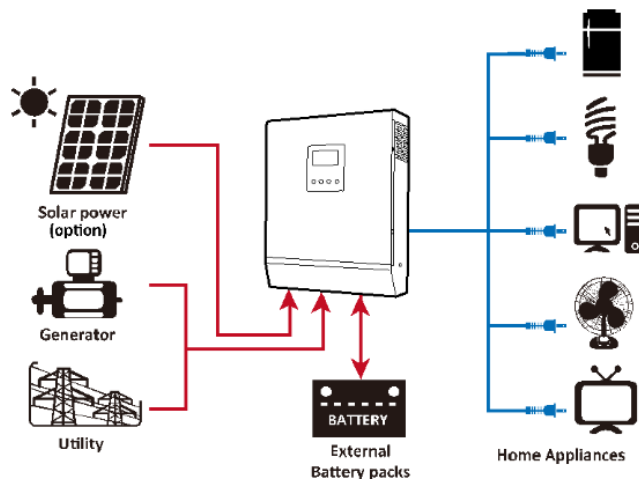
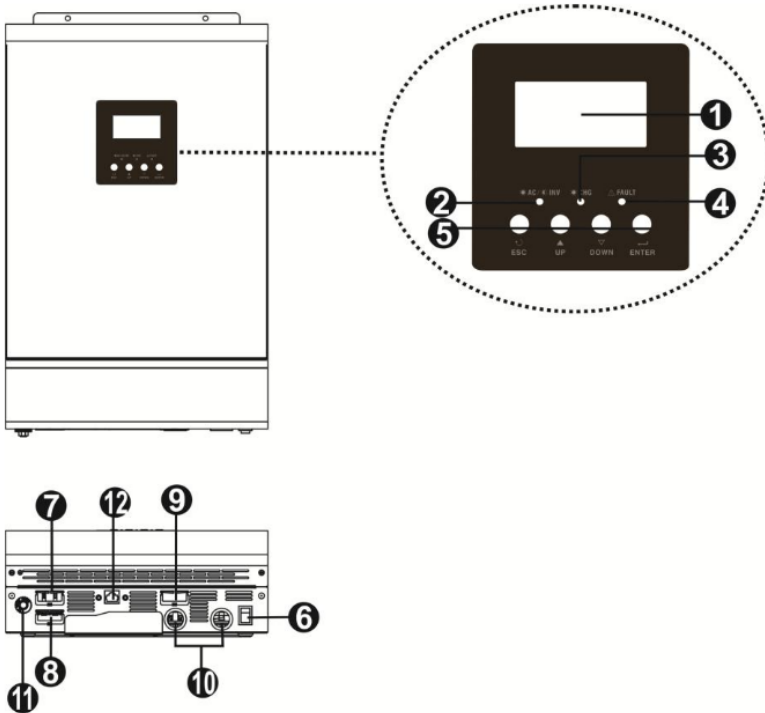

Figure 1 Hybrid Power System

Note: Appliances such as air conditioner are required at least 2~3 minutes to restart because it's required to have enough time to balance refrigerant gas inside of circuits. If a power shortage occurs and recovers in a short time, it will cause damage to your connected appliances. To prevent this kind of damage, please check manufacturer of air conditioner if it's equipped with time-delay function before installation. Otherwise, this inverter/charger will trig overload fault and cut off output to protect your appliance but sometimes it still causes internal damage to the air conditioner.

Product Overview



1. LCD display
2. Status indicator
3. Charging indicator
4. Fault indicator
5. Function buttons
6. Power on/off switch
7. AC input
8. AC output
9. PV input
10. Battery input
11. Circuit breaker
12. RS-232 communication port

Operation Diagrams and Working Conditions

Abbreviation:

I_{UCr} , charging current from AC charger

I_{SCr} , charger current from solar charger

I_{CHGr} , total charging current of battery

I_{DISCr} , discharging current from battery

I_{LOADr} , output current of AC load

CSF, Solar Charge First

CUF, Utility Charge First

CS+UF, Solar & Utility Charge at the same time

OSF, Output Solar First

OUF, Output Utility First

The device working status is determined by the states of inputs, the power on/off status, charging priority and output priority setting. Please refer to the following table for the device's work state.

Solar	Utility	Battery	Power on/off Switch	Output Priority	Charge Priority	State
--	LOSS	OK	ON	--	--	BAT AC OUTPUT
OK	LOSS	LOW	--	--	--	SOLAR CHARGE WITHOUT OUTPUT
OK	LOSS	OK	OFF	--	--	SOLAR CHARGE WITHOUT OUTPUT
LOSS	OK	--	--	--	CUF,CS+UF	AC CHARGE
LOSS	OK	--	--	--	CSF	NO CHARGE
OK	OK	LOW	--	--	CUF	AC CHARGE
OK	OK	LOW	ON	--	CSF	SOLAR CHARGE WITH OUTPUT
OK	OK	LOW	OFF	--	CSF	SOLAR CHARGE WITHOUT OUTPUT
OK	OK	LOW	--	--	CS+UF	AC & SOLAR CHARGE
OK	OK	OK	OFF	OSF	CSF	SOLAR CHARGE WITHOUT OUTPUT
OK	OK	OK	OFF	OSF	CUF	AC CHARGE
OK	OK	OK	OFF	OSF	CS+UF	AC & SOLAR CHARGE
OK	OK	OK	ON	OSF	--	BAT MODE
OK	OK	OK	--	OUF	CUF	AC CHARGE
OK	OK	OK	ON	OUF	CSF	SOLAR CHARGE WITH OUTPUT
OK	OK	OK	OFF	OUF	CSF	SOLAR CHARGE WITHOUT OUTPUT
OK	OK	OK	--	OUF	CS+UF	AC & SOLAR CHARGE

1) BAT AC OUTPUT

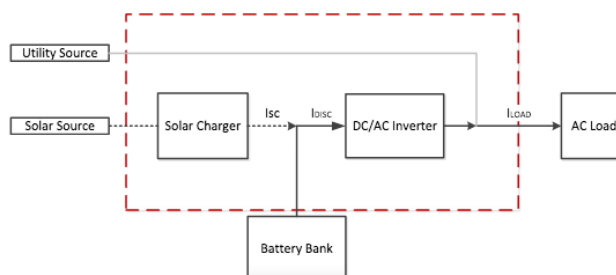

The load is powered by battery power and solar power. Solar charger works when solar power is OK. The maximum I_{SC} will go up to 50Amp. Then, the status of solar power and connected load will determine if battery is charge or discharge.

2) SOLAR CHARGE WITHOUT OUTPUT

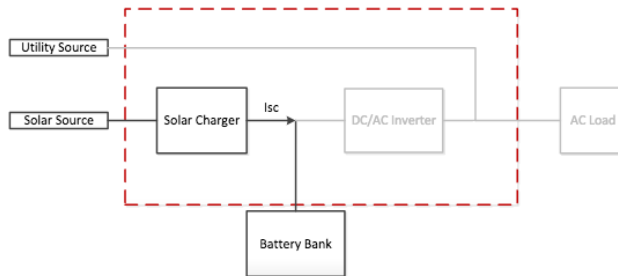

Solar charges the battery. The Max. I_{SC} goes up to 50Amp if solar panel with enough energy. No load is powered at this state.

3) SOLAR CHARGE WITH OUTPUT

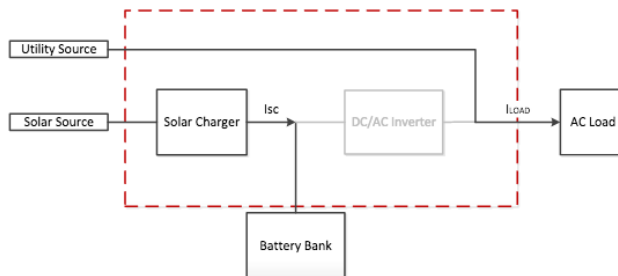

The load is powered by the utility. Solar power charges the battery. The maximum I_{SC} will go up to 50Amp if enough energy is generated by solar modules.

4) AC CHARGE

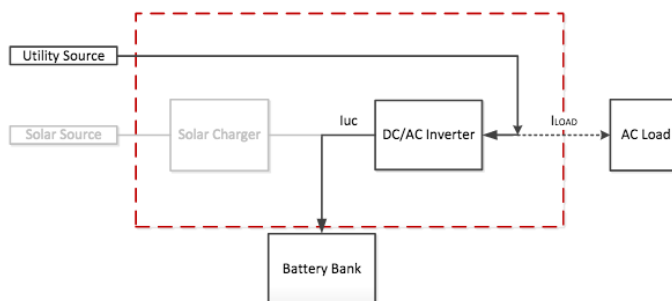

The battery is charged by the utility. The maximum I_{UC} is 30Amp. The solar charger doesn't work. When the power ON/OFF switch is turned "ON", the device will generate output to the load. When the power ON/OFF switch is turned "OFF", the device won't generate output to the load.

5) AC & SOLAR CHARGE

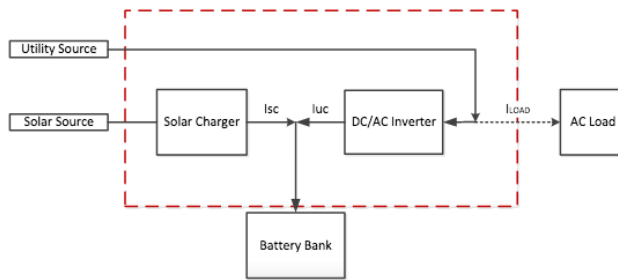

The battery is charged by the utility and solar power at the same time. $I_{CHG} = I_{UC} + I_{SC}$ and the maximum I_{CHG} is 50Amp. When the power ON/OFF switch is turned "ON", the device will generate output to the load. If the power ON/OFF switch is turned "OFF", the device won't generate output to the load.

6) NO CHARGE

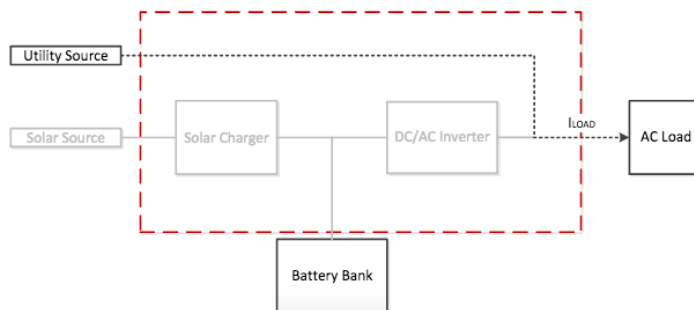

When the power ON/OFF switch is turned "ON", the device will generate output to the load. If the power ON/OFF switch is turned "OFF", the device won't generate output to the load. There is no charging current to the battery.

INSTALLATION

Unpacking and Inspection

Before installation, please inspect the unit. Be sure that nothing inside the package is damaged. You should have received the following items inside of package:

- The unit x 1
- User manual x 1
- Communication cable x 1

Preparation

Before connecting all wirings, please take off bottom cover by removing two screws as shown below.

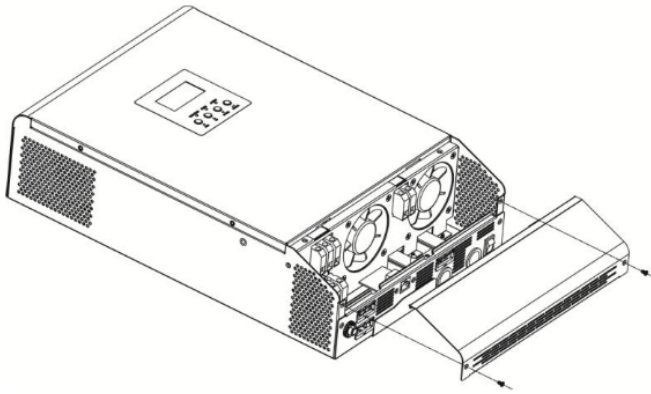

Mounting the Unit

Consider the following points before selecting where to install:

- Do not mount the inverter on flammable construction materials.
- Mount on a solid surface
- Install this inverter at eye level in order to allow the LCD display to be read at all times.
- For proper air circulation to dissipate heat, allow a clearance of approx. 10 cm to the side and approx. 50 cm above and below the unit.
- The ambient temperature should be between 0°C and 55°C to ensure optimal operation.
- The recommended installation position is to be adhered to the wall vertically.
- Be sure keep other objects and surfaces as shown in the below diagram to guarantee sufficient heat dissipation and to have enough space for removing wires.

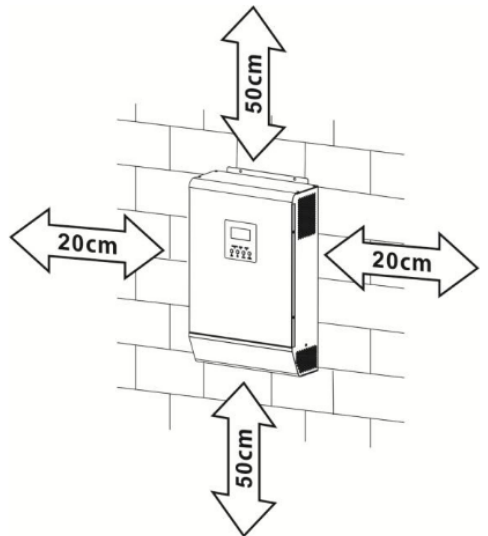

SUITABLE FOR MOUNTING ON CONCRETE OR OTHER NON-COMBUSTIBLE SURFACE ONLY.

Install the unit by screwing three screws.

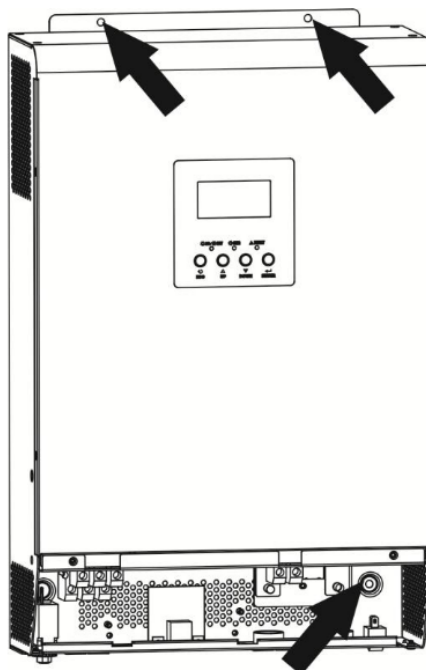

Battery Connection

CAUTION: To safety operation and regulation compliance, it's requested to install a separate DC over-current protector or disconnect device between battery and inverter. It may not be requested to have a disconnect device in some applications, however, it's still requested to have over-current protection installed. Please refer to typical amperage in below table as required fuse or beaker size.

WARNING! All wiring must be performed by a qualified personnel.

WARNING! It's very important for system safety and efficient operation to use appropriate cable for battery connection. To reduce risk of injury, please use the proper recommended cable and terminal size as below.

Recommended battery cable and terminal size:

Model	Typical Amperage	Battery capacity	1~3 m one-way	Ring Type for Cable Terminal	Torque value
4KVA	67A	200AH	1*4AWG	KST: RNBS22-6	2~ 3 Nm
			2*8AWG	KST: RNBS14-6	
5KVA	84A	200AH	1*4AWG	KST: RNBS22-6	2~ 3 Nm
			2*8AWG	KST: RNBS14-6	

Please follow below steps to implement battery connection:

1. Assemble battery ring terminal based on recommended battery cable and terminal size.
2. This model supports 48VDC system. It's suggested to connect at least 200Ah capacity battery.

NOTE: Please only use sealed lead acid battery or sealed GEL/AGM lead-acid battery.

3. Insert the ring terminal of battery cable flatly into battery connector on the inverter and make sure the bolts are tightened to a torque of 2-3 Nm. Make sure polarity at both the battery and the inverter/charge is correctly connected and ring terminals are tightly screwed to the battery terminals.

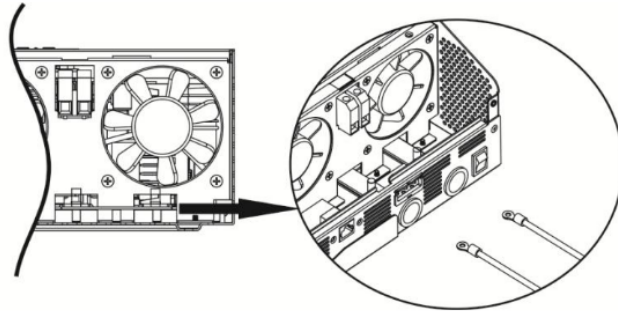

WARNING: Shock Hazard
Installation must be performed with care due to high battery voltage in series.

CAUTION!! Do not place anything between the flat part of the inverter terminal and the ring terminal. Otherwise, overheating may occur.
CAUTION!! Do not apply anti-oxidant substance on the terminals before terminals are connected tightly.
CAUTION!! Before making the final DC connection or closing DC breaker/disconnector, be sure positive (+) must be connected to positive (+) and negative (-) must be connected to negative (-).

AC Input/Output Connection

CAUTION!! Before connecting to AC input power source, please install a **separate** AC breaker between inverter and AC input power source. This will ensure the inverter can be securely disconnected during maintenance and fully protected from over current of AC input. The recommended spec of AC breaker is 40A for 4KVA and 50A for 5KVA.

CAUTION!! There are two terminal blocks with "IN" and "OUT" markings. Please do NOT mis-connect input and output connectors.

WARNING! All wiring must be performed by a qualified personnel.

WARNING! It's very important for system safety and efficient operation to use appropriate cable for AC input connection. To reduce risk of injury, please use the proper recommended cable size as below.

Suggested cable requirement for AC wires

Model	AWG no.	Torque
4KVA	10 AWG	1.4~1.6Nm
5KVA	8 AWG	1.4~1.6Nm

Please follow below steps to implement AC input/output connection:

1. Before making AC input/output connection, be sure to open DC protector or disconnector first.
2. Remove insulation sleeve 10mm for six conductors. And shorten phase L and neutral conductor N 3 mm.
3. Insert AC input wires according to polarities indicated on terminal block and tighten the terminal screws. Be sure to connect PE protective conductor (⊕) first.

L→LINE (brown or black)

⊕→Ground (yellow-green)

N→Neutral (blue)

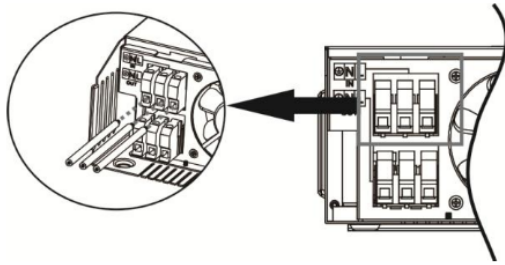

WARNING: Be sure that AC power source is disconnected before attempting to hardwire it to the unit.

4. Then, insert AC output wires according to polarities indicated on terminal block and tighten terminal screws.

Be sure to connect PE protective conductor (⊕) first.

L→LINE (brown or black)

⊕→Ground (yellow-green)

N→Neutral (blue)

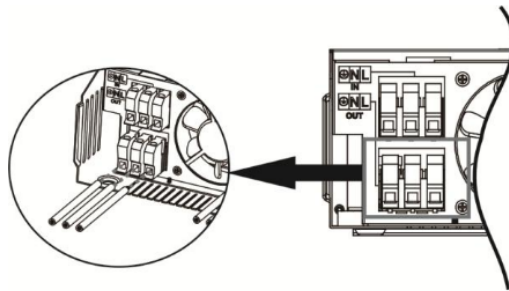

5. Make sure the wires are securely connected.

PV Connection (Only apply for the model with solar charger)

CAUTION: Before connecting to PV modules, please install **separately** a DC circuit breaker between inverter and PV modules.

WARNING! All wiring must be performed by a qualified personnel.

WARNING! It's very important for system safety and efficient operation to use appropriate cable for PV module connection. To reduce risk of injury, please use the proper recommended cable size as below.

Model	Typical Amperage	Cable Size	Torque
4KVA/5KVA	50A	8 AWG	1.4~1.6 Nm

Please follow below steps to implement PV module connection:

1. Remove insulation sleeve 10 mm for positive and negative conductors.
2. Check correct polarity of connection cable from PV modules and PV input connectors. Then, connect positive pole (+) of connection cable to positive pole (+) of PV input connector. Connect negative pole (-) of connection cable to negative pole (-) of PV input connector.

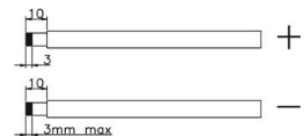

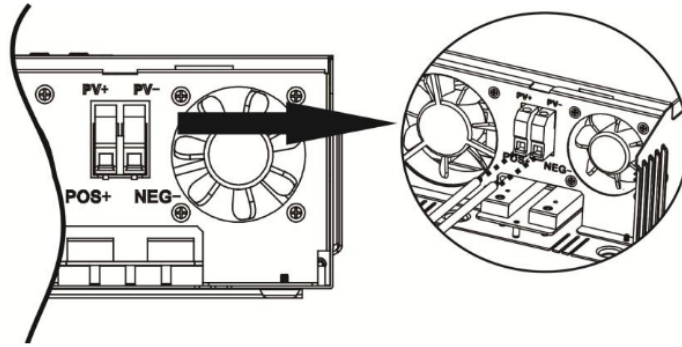

3. Make sure the wires are securely connected.

Final Assembly

After connecting all wirings, please put bottom cover back by screwing two screws as shown below.

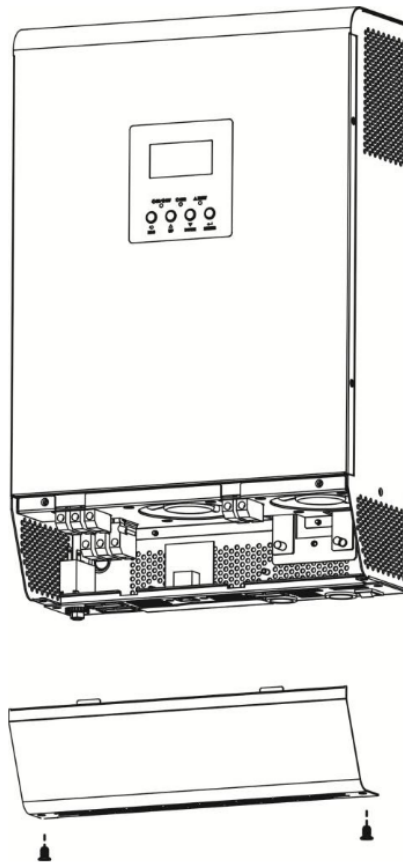

Communication Connection

This inverter/charger is equipped with a communication port to communicate with a PC with corresponding software. Please use supplied communication cable to connect to RS-232 of this inverter and RS-232 port of the PC. Please access software download site to download the monitoring software in your PC. Software download website: www.power-software-download.com/watchpower.html. For the detailed software operation, please check user manual of software.

OPERATION

Power ON/OFF

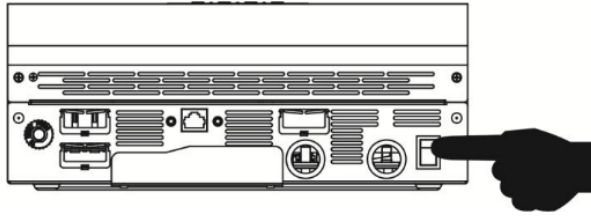

Once the unit has been properly installed and the batteries are connected well, simply press On/Off switch (located on the button of the case) to turn on the unit.

Operation and Display Panel

The operation and display panel, shown in below chart, is on the front panel of the inverter. It includes three indicators, four function keys and a LCD display, indicating the operating status and input/output power information.

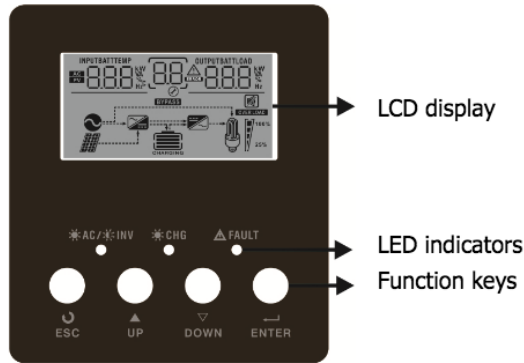

LED Indicator

LED Indicator		Messages	
☀ AC / ☀ INV	Green	Solid On	Output is available in bypass mode
		Flashing	Output is powered by battery in inverter mode
☀ CHG	Green	Solid On	Battery is fully charged
		Flashing	Battery is charging.
▲ FAULT	Red	Solid On	Fault mode
		Flashing	Warning mode

Function Keys

Function Key	Description
ESC	Exit setting mode
UP	To previous selection
DOWN	To next selection
ENTER	To confirm the selection in setting mode or enter setting mode

LCD Display Icons

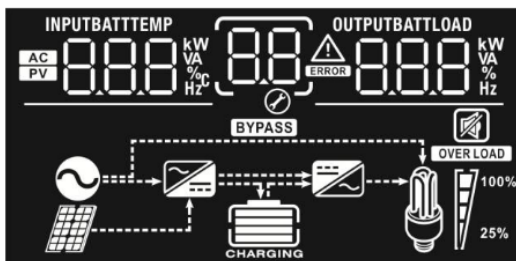

Icon	Function description	
Input Source Information		
AC	Indicates the AC input.	
PV	Indicates the PV input	
INPUTBATT 888 kW VA %C Hz	Indicate input voltage, input frequency, PV voltage, battery voltage and charger current.	
Configuration Program and Fault Information		
88	Indicates the setting programs.	
	Indicates the warning and fault codes.	
88 ⚠	Warning: 88 ⚠ flashing with warning code.	
88 ERROR	Fault: 88 ERROR lighting with fault code	
Output Information		
OUTPUTBATTLOAD 888 kW VA %C Hz	Indicate output voltage, output frequency, load percent, load in VA and load in Watt.	
Battery Information		
 CHARGING	Indicates battery level by 0-24%, 25-49%, 50-74% and 75-100% in battery mode and charging status in line mode.	
In AC mode, it will present battery charging status.		
Status	Battery voltage	LCD Display
Constant Current mode / Constant Voltage mode	<2V/cell	4 bars will flash in turns.
	2 ~ 2.083V/cell	Bottom bar will be on and the other three bars will flash in turns.
	2.083 ~ 2.167V/cell	Bottom two bars will be on and the other two bars will flash in turns.
	> 2.167 V/cell	Bottom three bars will be on and the top bar will flash.
Floating mode. Batteries are fully charged.		4 bars will be on.

In battery mode, it will present battery capacity.

Load Percentage	Battery Voltage	LCD Display
Load > 50%	< 1.717V/cell	
	1.717V/cell ~ 1.8V/cell	
	1.8 ~ 1.883V/cell	
	> 1.883 V/cell	
50% > Load > 20%	< 1.817V/cell	
	1.817V/cell ~ 1.9V/cell	
	1.9 ~ 1.983V/cell	
	> 1.983	
Load < 20%	< 1.867V/cell	
	1.867V/cell ~ 1.95V/cell	
	1.95 ~ 2.033V/cell	
	> 2.033	

Load Information

	Indicates overload.			
	Indicates the load level by 0-24%, 25-50%, 50-74% and 75-100%.			
	0%~25%	25%~50%	50%~75%	75%~100%

Mode Operation Information

	Indicates unit connects to the mains.
	Indicates unit connects to the PV panel.
	Indicates load is supplied by utility power.
	Indicates the utility charger circuit is working.
	Indicates the DC/AC inverter circuit is working.

Mute Operation

	Indicates unit alarm is disabled.
--	-----------------------------------

LCD Setting

After pressing and holding ENTER button for 3 seconds, the unit will enter setting mode. Press "UP" or "DOWN" button to select setting programs. And then, press "ENTER" button to confirm the selection or ESC button to exit.

Setting Programs:

Program	Description	Selectable option	
00	Exit setting mode	Escape 00 ESC	
01	Output source priority	Solar first: 01 SOL	Utility first (default): 01 UTI
02	Maximum charging current	10A: 02 10A	20A: 02 20A
		30A: 02 30A	40A: 02 40A
		50A (default): 02 50A	
03	AC input voltage range	Appliances(default): 03 APL	UPS: 03 UPS
04	Power saving mode	Saving disable(default): 04 SDS	Saving mode enable: 04 SEN
05	Battery type	AGM(default): 05 AGM	Flooded: 05 FLd
06	Auto restart when overload occurs	Restart disable(default): 06 LTd	Restart enable: 06 LTe
07	Auto restart when over temperature occurs	Restart disable(default): 07 tTd	Restart enable: 07 tTe
09	Output frequency	50Hz(default): 09 50 Hz	60Hz: 09 60 Hz
16	Charger source priority	Solar first: 16 CSO	Utility first: 16 CUT
		Solar and Utility(default): 16 SNU	

18	Alarm control	Alarm on(default): 18 60N	Alarm off: 18 60F
20	Backlight control	Backlight on(default): 20 L0N	Backlight off: 20 L0F
22	Beeps while primary source is interrupted	Alarm on(default): 22 A0N	Alarm off: 22 A0F
25	Record Fault code	Record enable: 25 FEN	Record disable(default): 25 FdS

Display Setting



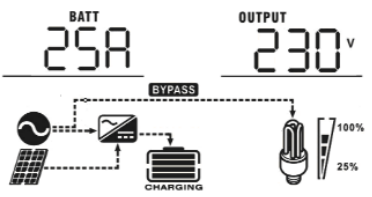
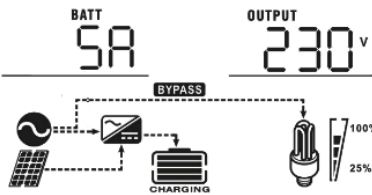
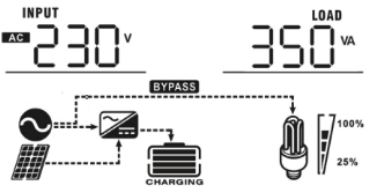
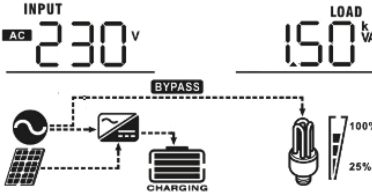
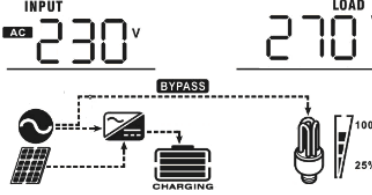
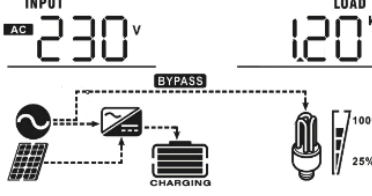

The LCD display information will be switched in turns by pressing "UP" or "DOWN" key. The selectable information is switched as below order: **input voltage, input frequency, battery voltage, charging current, PV voltage, output voltage, output frequency, load percentage, load in Watt, load in VA, CPU1 Version and CPU2 Version**

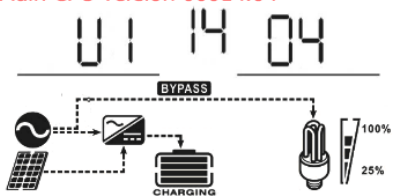
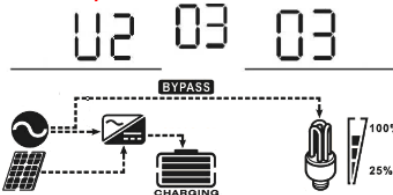
Selectable information	LCD display
Input voltage/Output voltage (Default)	Input Voltage=230V, output voltage=230V
Input frequency/Output frequency	Input frequency=50Hz, Output frequency=50Hz
Battery voltage/Output voltage	Battery voltage=25.5V
PV voltage/Load percentage	PV voltage=60V, Load percent=70%

<p>Charging current/Output voltage</p>	<p>Current $\geq 10A$</p>  <p>Current $< 10A$</p> 
<p>Input voltage/Load in VA</p>	<p>When load is lower than 1kVA, load in VA will presents 350V as below.</p>  <p>When load is larger than 1kVA ($\geq 1kVA$), load in VA will presents 1.5kVA as below:</p> 
<p>Input voltage/Load in Watt</p>	<p>When load is lower than 1kW, load in W will present 270W as below:</p>  <p>When load is larger than 1kW ($\geq 1kW$), load in W will present 1.2kW as below.</p> 

<p>Main CPU version checking</p>	<p>Main CPU version 00014.04</p> 
<p>Secondary CPU version checking</p>	<p>Secondary CPU version 00003.03</p> 

Operating Mode Description

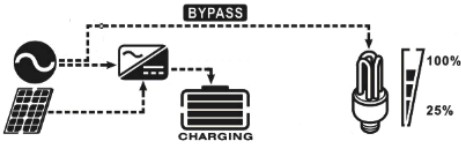
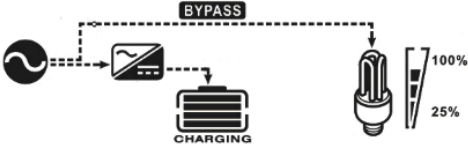

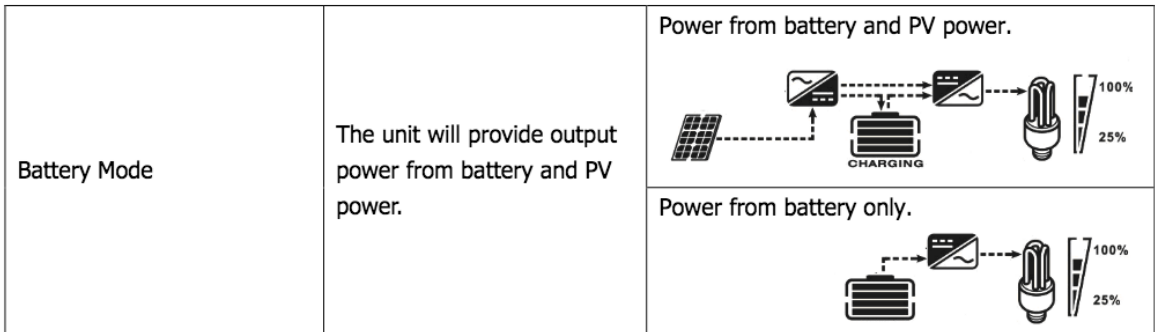

Operation mode	Description	LCD display
<p>Standby mode/ Fault mode/ Power saving mode</p>	<p>No output is supplied by the unit but it still can charge batteries.</p>	<p>Charging by utility and PV</p> 
		<p>Charging by utility</p> 
		<p>Charging by PV</p> 
		<p>No charging</p> 
<p>Line Mode</p>	<p>The unit will provide output power from the mains. It will also charge the battery at line mode.</p>	<p>Charging by utility and PV</p> 
		<p>Charging by utility</p> 



Fault Reference Code

Fault Code	Fault Event	Icon on
01	Fan is locked	
02	Over temperature	
03	Battery voltage is too high	
04	Battery voltage is too low	
05	Output short circuited or Over temperature	
06	Output voltage is too high	
07	Over load time out	
08	Bus voltage is too high	
09	Bus soft start failed	
11	Main relay failed	
51	Over current inverter	
52	Bus voltage is too low	
53	Inverter soft start failed	
54	Self-test failed	
55	Over DC voltage on output of inverter	
56	Battery connection is open	
57	Current sensor failed	
58	Output voltage is too low	

Warning Indicator

Warning Code	Warning Event	Audible Alarm	Icon flashing
01	Fan is locked	Beep three times every second	
03	Battery is over charged	Beep once every 1second	
04	Low battery	Beep once every 1 second	
07	Overload	Beep once every 0.5 second	
10	Power limitation	Beep twice every 3 seconds	

SPECIFICATIONS

Table 1 Line Mode Specifications

INVERTER MODEL	4KVA	5KVA
Input Voltage Waveform	Sinusoidal (utility or generator)	
Nominal Input Voltage	230Vac	
Low Loss Voltage	170Vac±7V (UPS); 90Vac±7V (Appliances)	
Low Loss Return Voltage	180Vac±7V (UPS); 100Vac±7V (Appliances)	
High Loss Voltage	280Vac±7V	
High Loss Return Voltage	270Vac±7V	
Max AC Input Voltage	300Vac	
Nominal Input Frequency	50Hz / 60Hz (Auto detection)	
Low Loss Frequency	40±1Hz	
Low Loss Return Frequency	42±1Hz	
High Loss Frequency	65±1Hz	
High Loss Return Frequency	63±1Hz	
Output Short Circuit Protection	Circuit Breaker	
Efficiency (Line Mode)	>95% (Rated R load, battery full charged)	
Transfer Time	10ms typical (UPS); 20ms typical (Appliances)	
Power Limitation	 <p>The graph illustrates the power limitation of the inverter. The vertical axis represents Output Power, and the horizontal axis represents Input Voltage. The power is zero for input voltages below 90V. At 90V, the power jumps to 50% of the rated power. From 90V to 170V, the power increases linearly to reach the full Rated Power. From 170V to 280V, the power remains constant at the Rated Power level. Above 280V, the power drops to zero.</p>	

Table 2 Invert Mode Specifications

INVERTER MODEL	4KVA	5KVA
Rated Output Power	4KVA/3.2KW	5KVA/4KW
Output Voltage Waveform	Pure Sine Wave	
Output Voltage Regulation	230Vac±5%	
Output Frequency	50Hz	
Peak Efficiency	90%	
Overload Protection	5s@≥150% load; 10s@110%~150% load	
Surge Capacity	2* rated power for 5 seconds	
Nominal DC Input Voltage	48Vdc	
Cold Start Voltage	46.0Vdc	
Low DC Warning Voltage @ load < 20% @ 20% ≤ load < 50% @ load ≥ 50%	44.0Vdc 42.8Vdc 40.4Vdc	
Low DC Warning Return Voltage @ load < 20% @ 20% ≤ load < 50% @ load ≥ 50%	46.0Vdc 44.8Vdc 42.4Vdc	
Low DC Cut-off Voltage @ load < 20% @ 20% ≤ load < 50% @ load ≥ 50%	41.0Vdc 40.8Vdc 38.4Vdc	
High DC Recovery Voltage	54Vdc	
High DC Cut-off Voltage	56Vdc	
No Load Power Consumption	<50W	
Saving Mode Power Consumption	<15W	

Table 3 Charge Mode Specifications

INVERTER MODEL	4/5KVA
Charging Algorithm	2-Step
Utility Charging Mode	
Charging Current (UPS)	20/30Amp
Charging Floating Voltage	54Vdc
Solar Charging Mode	
Charging Current (PWM)	50Amp
System DC Voltage	48Vdc
Max. PV Array Open Circuit Voltage	125Vdc
Standby Power Consumption	2W
DC Voltage Accuracy	+/-0.3%

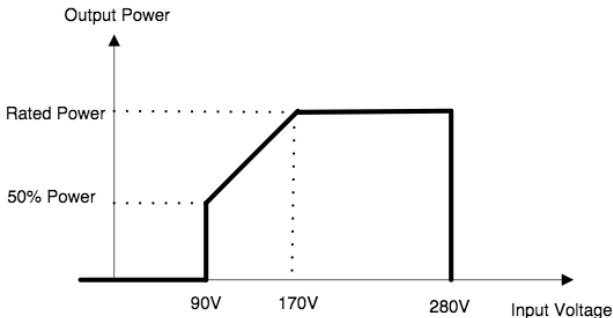
Table 4 General Specifications

INVERTER MODEL	4KVA/5KVA
Safety Certification	CE
Operating Temperature Range	0°C to 55°C
Storage temperature	-15°C~ 60°C
Dimension (D*W*H), mm	468 * 295 * 120
Net Weight, kg	10

Charging Controls

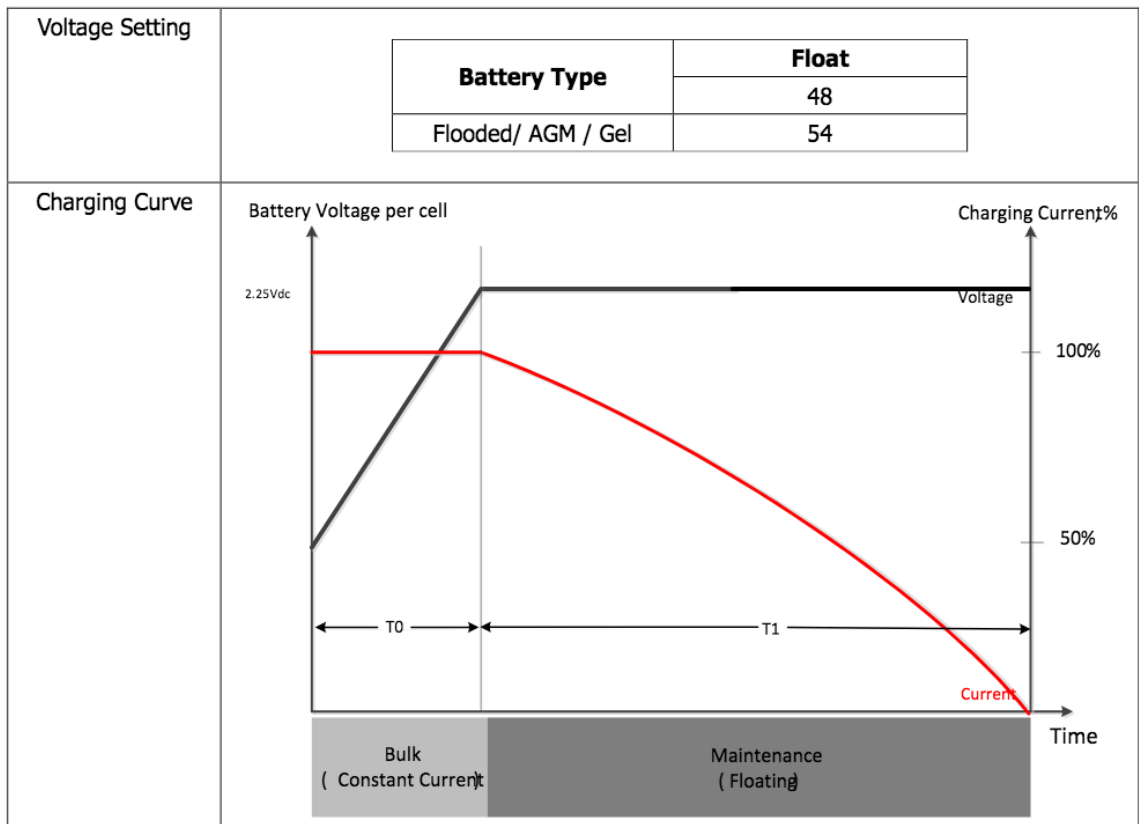

TROUBLE SHOOTING

Problem	LCD/LED/Buzzer	Explanation / Possible cause	What to do
Unit shuts down automatically during startup process.	LCD/LEDs and buzzer will be active for 3 seconds and then complete off.	The battery voltage is too low (<1.91V/Cell)	1. Re-charge battery. 2. Replace battery.
No response after power on.	No indication.	1. The battery voltage is far too low. (<1.4V/Cell) 2. Battery polarity is connected reversed.	1. Check if batteries and the wiring are connected well. 2. Re-charge battery. 3. Replace battery.
Mains exist but the unit works in battery mode.	Input voltage is displayed as 0 on the LCD and green LED is flashing.	Input protector is tripped	Check if AC breaker is tripped and AC wiring is connected well.
	Green LED is flashing.	Insufficient quality of AC power (Shore or Generator)	1. Check if AC wires are too thin and/or too long. 2. Check if generator (if applied) is working well, or check if input voltage range setting is correct (UPS→Appliance)
	Green LED is flashing.	Set Solar power as the priority of output source	Change output source priority to Utility first.
When the unit is turned on, internal relay is switched on and off repeatedly.	LCD display and LEDs are flashing.	Battery is disconnected.	Check if battery wires are connected well.
Buzzer beeps continuously and red LED is on.	Fault code 07.	Overload error. The inverter is loaded with more than 110% load and time is up	Reduce the connected load by switching off some equipment.
	Fault code 05.	Output short circuited.	Check if wiring is connected well and remove abnormal load.
		Temperature of internal converter component is over 120°C.	Check whether the air flow of the unit is blocked or whether the ambient temperature is too high.
	Fault code 02.	Internal Inverter component over 100°C	
	Fault code 03.	Battery is over charged.	Return to repair center.
		The battery voltage is too high.	Check if spec and quantity of batteries are meet requirements.
	Fault code 01.	Fan fault	Replace the fan.
	Fault code 06.	Output abnormal (Inverter voltage below than 190Vac or is higher than 260Vac)	1. Reduce the connected load. 2. Return to repair center
	Fault code 08.	Internal components failed.	Return to repair center
Fault code 09.			

Appendix: Approximate Back-up Time Table

Model	Load (VA)	Backup Time @ 12Vdc 100Ah (min)	Backup Time @ 12Vdc 200Ah (min)
4KVA	400	766	1610
	800	335	766
	1200	198	503
	1600	139	339
	2000	112	269
	2400	95	227
	2800	81	176
	3200	62	140
	3600	55	125
	4000	50	112

Model	Load (VA)	Backup Time @ 12Vdc 100Ah (min)	Backup Time @ 12Vdc 200Ah (min)
5KVA	500	613	1288
	1000	268	613
	1500	158	402
	2000	111	271
	2500	90	215
	3000	76	182
	3500	65	141
	4000	50	112
	4500	44	100
	5000	40	90

Note: Backup time depends on the quality of the battery, age of battery and type of battery.
Specifications of batteries may vary depending on different manufacturers.